

1 2 3 4 5 6

A

B

C

D

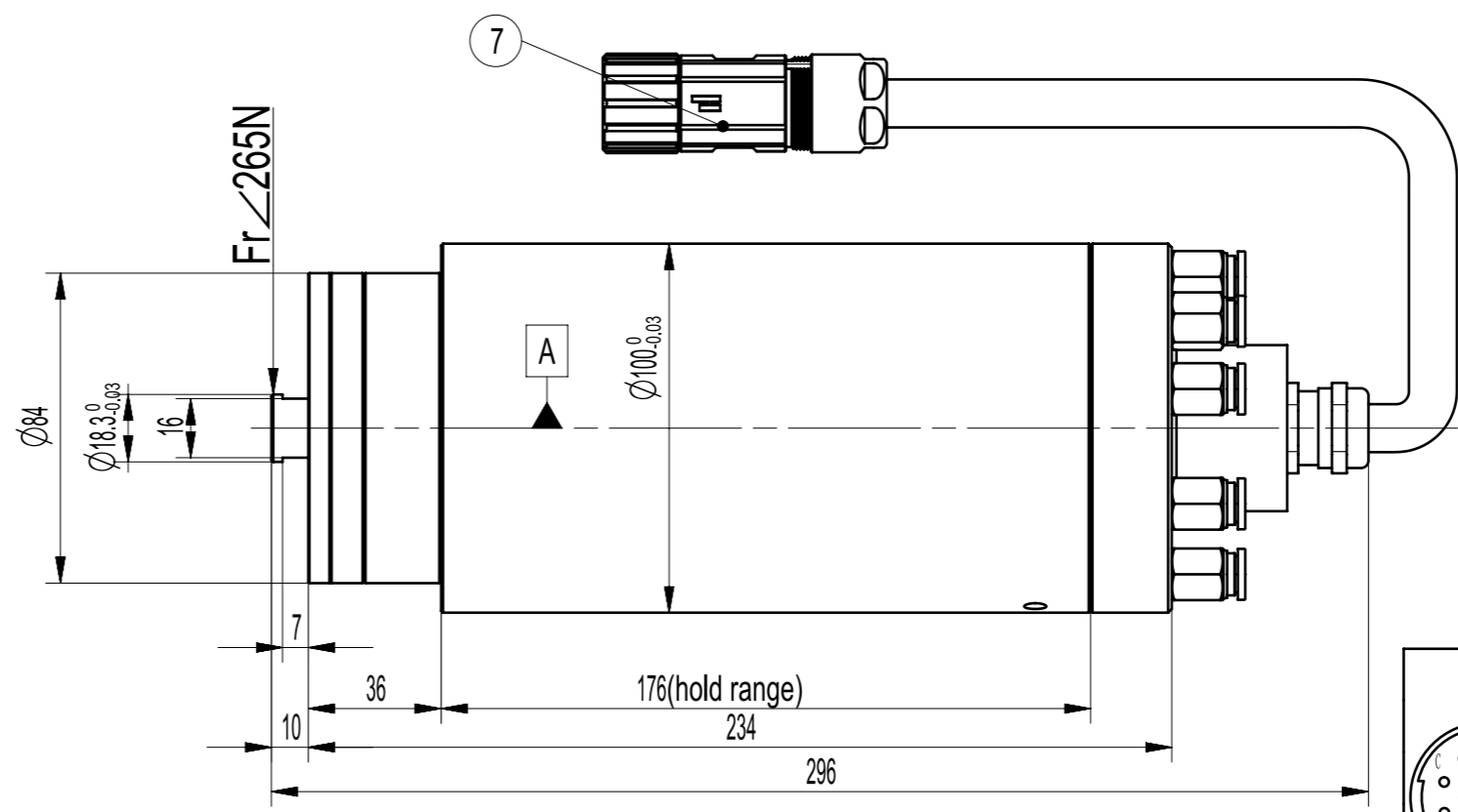
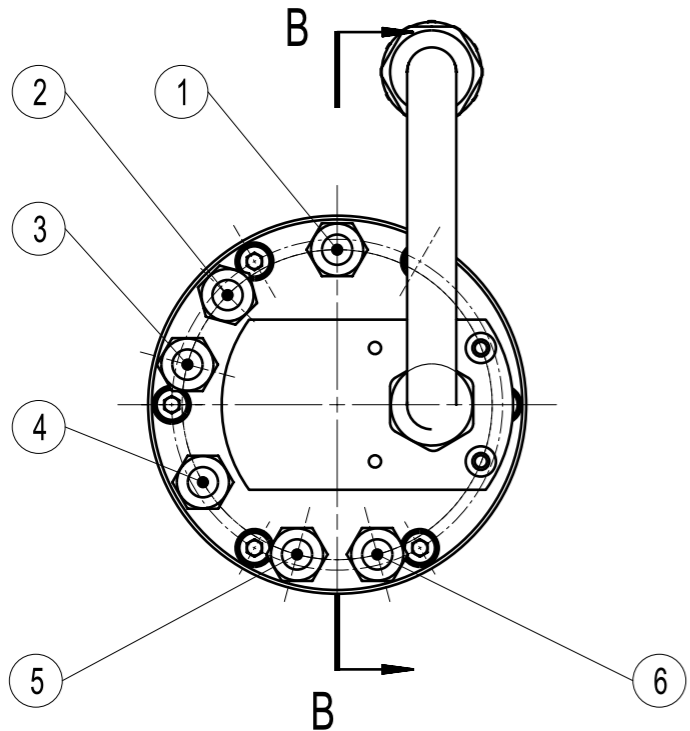

SECTION B-B

Power Connector			
1	phase U	A	PT1000(motor)
2	phase V	B	PT1000(motor)
3	phase W	C	PT100(bearing)
⊖	GND	D	PT100(bearing)

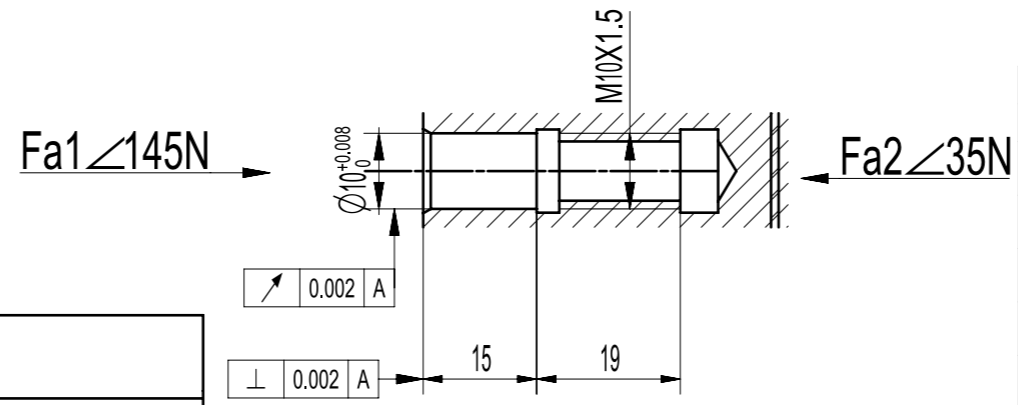
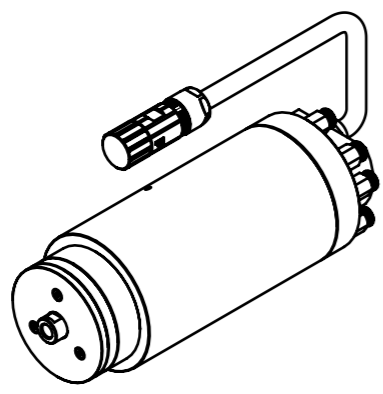

connection discription			
No.	function	interface	discription
1	water outlet	G1/4	hose diameter 8X6
2	oil air inlet	G1/8	hose diameter 6X4,1-2bar
3	oil air inlet	G1/8	hose diameter 6X4,1-2bar
4	air seal	G1/8	hose diameter 6X4,1bar
5	exhaust oil	G1/4	hose diameter 8X6
6	water inlet	G1/4	hose diameter 8X6
7	Power connector	M23	

spindle specification				
speed	90000		r/min	radial rigidity (N/μm) 38.7
Power(S1)	2.5		kW	axial rigidity(N/μm) 38
Power(S6,40%)	3		kW	tilt angle(°) ±90
Voltage	350		V	
Current(S1)	7.5		A	
Current(S6,40%)	8		kW	
frequency	1500		Hz	
motor type	Asynchronous			
lubrecation	oil-air			
lubricant	ISO VG22			
gas filtering requirements	Solids:5 micron,residual oil content:0.5mg/m^3			
spindle coolant	Rust resistant cooling water, flow rate 3L/min@25°C			

未注尺寸公差		00	主轴外形图		1					
注：孔取(+),轴取(-)		件号	名称		数量	材料		硬度		
尺寸/mm										
大于	至	公差								
-	6	±0.05								
6	30	±0.10								
30	120	±0.15								
120	250	±0.25								
250	500	±0.35								
500	1000	±0.45								
1000	1600	±0.55								
1600	2000	±0.65								
更改号	签字	日期								

LYJSD 100MD90Y2.5

设计		比例		重量	
校对		1:2			
标准化审核					
工艺会签					
审核					
批准					

1 2 3 4 5 A3