

connection discription			
No.	function	interface	discription
1	water outlet	G1/4	equiped with piping fitting,hose diameter 8X6
2	air seal	G1/8	equiped with piping fitting,hose diameter 6X4,1bar
3	Speed sensor	M8X1	PNP proxmicity switch,3 core cable,1.5m lenth
4	water inlet	G1/4	equiped with piping fitting,hose diameter 8X6
5	Power connector	M40	

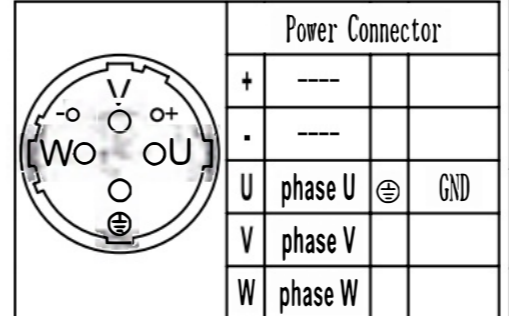

Spindle Specification					
Speed	3000	7500	15000	20000	r/min
Power	1.4	3.7	3.7	3.7	kW
Voltage	60	190	350	350	V
Current	18	17	11	9.5	A
Frequency	100	250	500	666.7	Hz
Torque	4.5	4.7	2.3	1.7	Nm
Motor Type	Induction motor				
Lubrication	Grease				
gas filtering requirements	Solids:5 micron,residual oil content:0.5mg/m ³				
Spindle coolant	Rust resistant cooling water, flow rate 3L/min@25°C				

未注尺寸公差		00	主轴外形图		1				
注:孔取(+),轴取(-)		件号	名称		数量	材料	硬度	备注	
尺寸/mm									
大于	至	公差							
-	6	±0.05							
6	30	±0.10							
30	120	±0.15							
120	250	±0.25							
250	500	±0.35							
500	1000	±0.45							
1000	1600	±0.55							
1600	2000	±0.65							
更改号	签字	日期							

LYJSD 150ZD20G3.7

设计	比例	重量
校对	1:2.5	
标准化审核		
工艺会签		
审核		
批准		