

Spindle specification

Winding Connex	star-Y		delta-			
	SPEED	3500	8500	7500		15000
Frequency	175	425	375	750		Hz
Power(S1)	45	45	45	45		kW
Torque(S1)	122.8	50.6	57.3	28.7		Nm
Voltage	320	380	380	380		V
Current(S1)	105	96	58	51		A
Motor type	Induction motor		Encoder	256 teeth, m=0.4, output 1Vpp, SIN/COS		
Lubricant	Grease		Rotation	right and left		
Operating position	horizontal to vertical		Front seal	Protecting air flow, 1-1.5bar		
ATC cylinder	hydraulic pressure unclamp 80bar, air pressure clamp 5bar					
Interface	SK40 DIN69871/69872, Pull force 14000N					
Air quality	Filtration and drying, particle size 5 microns, residual oil content 0.5mg/m ³					
Spindle Coolant	Water flow rate 10L/min@25°C					

ATC&Temperature Connector					
1	bearing PT100	7	10-30VDC	13	---
2	bearing PT100	8	Clamp without tool	14	motor PT1000
3	---	9	0V	15	motor PT1000
4	10-30VDC	10	10-30VDC	16	Shield
5	Unclamp tool	11	Clamp tool	17	---
6	0V	12	0V		---

Encoder Connector			
1	B-	7	Shield
2	--	8	B+
3	Z+	9	--
4	Z-	10	0V
5	A+	11	-
6	A-	12	+5V

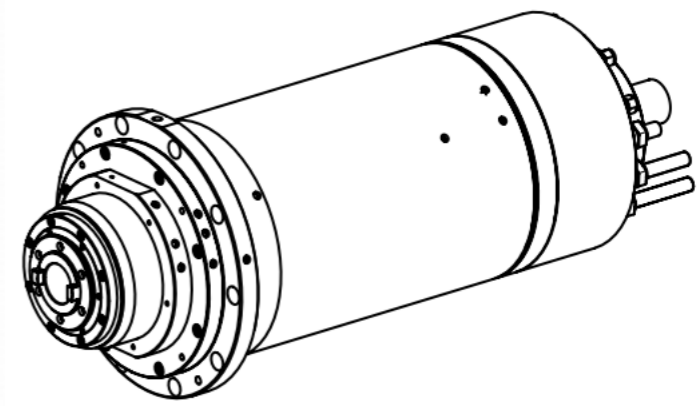

未注尺寸公差		-		主轴确认图							
注: 孔取(+), 轴取(-)	件号	名称	数量	材料	硬度	备注					
尺寸/mm											
大于	至	公差									
-	6	±0.05									
6	30	±0.10									
30	120	±0.15									
120	250	±0.25									
250	500	±0.35									
500	1000	±0.45									
1000	1600	±0.55									
1600	2000	±0.65	更改号	签字	日期	批	准				

LYJSD 260XDJ15G45

比例 1:5 重量